

ELEVATOR - MAINTENANCE PRACTICES

1. General

- A. This section includes maintenance practices for the removal/installation of the elevator system and the elevator system rigging procedures.

2. Elevator System Removal/Installation

- A. Remove the Elevator System (Refer to Figure 201).

- (1) Remove the carpet or vinyl cover, plywood floor covers, floorboard access covers, and upholstery panel to get access to the tailcone.
- (2) If installed, remove the liquid barrier. Refer to Chapter 53, Plates/Skins - Maintenance Practices.
- (3) Remove the cotter pins, nuts, washers and bolts, then disconnect the pushrod from the support arm and the bell crank.
- (4) Remove the bolts, washers and nuts, then remove the upper and lower links from the forward bell crank and cables.
- (5) Remove the bolt and washers, then disconnect the forward bell crank from the support.
- (6) Remove the nuts, washers and bolts, then remove the pulleys from the supports.
- (7) Remove the nuts, washers and bolts, then disconnect the fairleads from the supports (Airplanes 20800001 thru 20800185 and 208B0001 thru 208B0214 not incorporating SK208-76).

NOTE: Airplanes 20800186 and On and 208B0215 and On, and airplanes incorporating SK208-76 do not have the fairleads installed.

- (8) Remove the nuts, washers and bolts, then disconnect the pulleys from the supports.
- (9) Remove the safety wire or clips and disconnect the turnbuckles from the cables.
- (10) Remove the nuts, washers and bolts, then remove the right and left links from the cables and the aft bell crank.
- (11) Remove the cotter pins, nuts, washers and bolts, then disconnect the pushrod from the bell crank and the elevator pushrod arm.
- (12) Remove the cotter pins, nut, washer, races, bearings, spacer and bolt, then disconnect the aft bell crank from the support.

NOTE: To make the removal and installation of the cables easy, attach a length of wire on the opposite end of the removal end of the cable. When the cable is removed, leave the wire in position to route the cable through the airplane structure. Pull the replacement cable into the correct location with the wire.

- (13) Remove the cables from the airplane.

- B. Install the Elevator System (Refer to Figure 201).

- (1) Install the cables in the airplane.
- (2) Attach the aft bell crank to the support, then install the spacer, bolt, races, bearings, washer, nut and cotter pins.
- (3) Attach the pushrod to the aft bell crank and the elevator pushrod arm, then install the bolts, washers, nuts and cotter pins.
 - (a) Install the pushrod so that the placard is on the lower forward end to facilitate inspections.
- (4) Attach the forward bell crank to the support, then install the bolts and washers.
- (5) Connect the pushrod to the support arm and the forward bell crank, then install the bolts, washers, nuts and cotter pins.
- (6) Connect then links to the forward bell crank and cables, then install the bolts, washers and nuts.
- (7) Attach the pulleys to the support, then install the bolts, washers and nuts.
- (8) Connect the fairleads to the support, then install the bolts, washers and nuts (Airplanes 20800001 thru 20800185 and 208B0001 thru 208B0214 not incorporating SK208-76).

NOTE: Airplanes 20800186 and On and 208B0215 and On, and airplanes incorporating SK208-76 do not have the fairleads installed.

- (9) Attach the pulleys to the supports, then install the bolts, washers and nuts.
- (10) Attach the links to the forward bell crank and cables, then install the bolts, washers and nuts.

- (11) Connect the cables to the turnbuckles that connect the up and down cables to the forward and aft bell cranks.
- (12) Tighten the turnbuckles gradually to set the cable tension at 55 to 65 pounds, then safety the cables with wire or install clips on the turnbuckles.

WARNING: Make sure that elevators move in correct direction while actuating control column forward and aft. Also, check for crossed or wrapped cables.

- (13) Adjust the elevator system rigging. Refer to Elevator System Rigging.
- (14) If previously installed, install the liquid barrier. Refer to Chapter 53, Plates/Skins - Maintenance Practices.
- (15) Install the upholstery panel at the entrance to the tailcone, floorboard access covers, plywood floor covers, carpet and the vinyl covers.

3. Elevator System Rigging

- A. Rig the Elevator System (Refer to Figure 201).

NOTE: All control surface cable tensions should be rigged at an ambient temperature of 70°F. When the temperature has been stable for four hours, then you can set the cable tensions.

- (1) Remove the control lock and replace it with an elevator neutral rigging tool.
- (2) Remove the upholstery panel from the entrance to the tailcone.
- (3) If installed, remove the liquid barrier. Refer to Chapter 53, Plates/Skins - Maintenance Practices.
- (4) Remove the safety wire, then loosen the turnbuckles that connect the up and down cables to the bell crank.
- (5) Use the elevator rigging protractor to set the elevator in the neutral position, then tighten the turnbuckles sufficiently to attach the elevator in the neutral position.
- (6) Attach the inclinometer to the elevator, then set the elevator in the zero position.
- (7) Tighten the turnbuckles until the elevator cannot be moved from the zero setting.
- (8) Remove the access covers 212FR and 211EL (Airplanes 20800130 and On and 208B0087 and On). Refer to Chapter 6, Access Plates and Panels Identification - Maintenance Practices.
- (9) Remove the elevator neutral rigging tool, then set the elevator to 18 to 22 degrees in the DOWN position on the elevator rigging protractor.

NOTE: You can adjust the DOWN Stop bolt if necessary.

- (10) With the rigging protractor, make sure that the elevator UP Stop is set as follows:

Table 201. Model 208 UP Stop Limits

Model	TKS Anti-ice System	Elevator Up Stop Setting	Plus Tolerance	Minus Tolerance
208	Not Installed	25°	+2°	-2°
	Installed	18°	+1°	-1°

NOTE: If necessary, adjust the UP Stop bolt.

Table 202. Model 208B UP Stop Limits

Model	TKS Anti-ice System	Elevator Up Stop Setting	Plus Tolerance	Minus Tolerance
208B	Not Installed	25°	+2°	-2°
Airplanes 208B0001 thru 208B4999	Installed	22°	+1°	-0°
Airplanes 208B5000 and On	Installed	24°	+0°	-1°

NOTE: If necessary, adjust the UP Stop bolt.

- (11) For Airplanes 20800130 and On and 208B0087 and On, remove or install stop blocks as necessary for full normal up travel and to get the same dimensions that are shown in Detail G.
- (12) Attach the tensiometer to the elevator cables, then do a check of the elevator tension settings in at more than one location.

- (13) Set the cable tension to 55 to 65 pounds, then safety the turnbuckles with wire.
- (14) Remove the tensiometer from the elevator cable, then replace the upholstery panel at the entrance to the tailcone.
- (15) Install the access covers if they were removed. Refer to Chapter 6, Access Plates and Panels Identification - Maintenance Practices.
- (16) If previously installed, install the liquid barrier. Refer to Chapter 53, Plates/Skins - Maintenance Practices.
- (17) Do a check of the friction band, then replace the control lock after you complete the check of the friction band. Refer to Friction Band Check.

4. Friction Band Check

A. Do a Check of the Friction Band

NOTE: All friction band measurements must be done with the load applied to a load scale parallel to the direction of movement of the control column. The control column movement must be slow and stable over the full range of travel.

- (1) With the control tube one inch forward of the neutral position, make a load scale reading as the column crosses the neutral position.
 - (a) Identify this reading as F1.
- (2) With control tube one inch aft of neutral position, make a load scale reading in the opposite direction.
 - (a) Identify this reading as F2.

NOTE: If during step 2 the control tube moves forward by itself after being released from the starting point, then subtract the F2 reading from the F1 reading.

- (3) The sum of the F1 reading and the F2 reading equals the friction band.
- (4) The friction band should be set at 15 pounds maximum without the autopilot installation, and set at 20 pounds maximum with the autopilot installation.

NOTE: If the friction band is more than the acceptable limit, do the checks that follow:

- (a) Do a check of the elevator cable tension to make sure it is set it at 60 +5 or -5 pounds (266.89 +22.24 or - 22.24 N).
- (b) Do a check of the alignment of the pulleys and cables.
- (c) Do a check for binding of the pulleys and cables.
- (d) Make sure there is no interference with pulleys and cables and the airplane structure or adjacent cables.

Figure 201 : Sheet 1 : Elevator System Installation

A22604

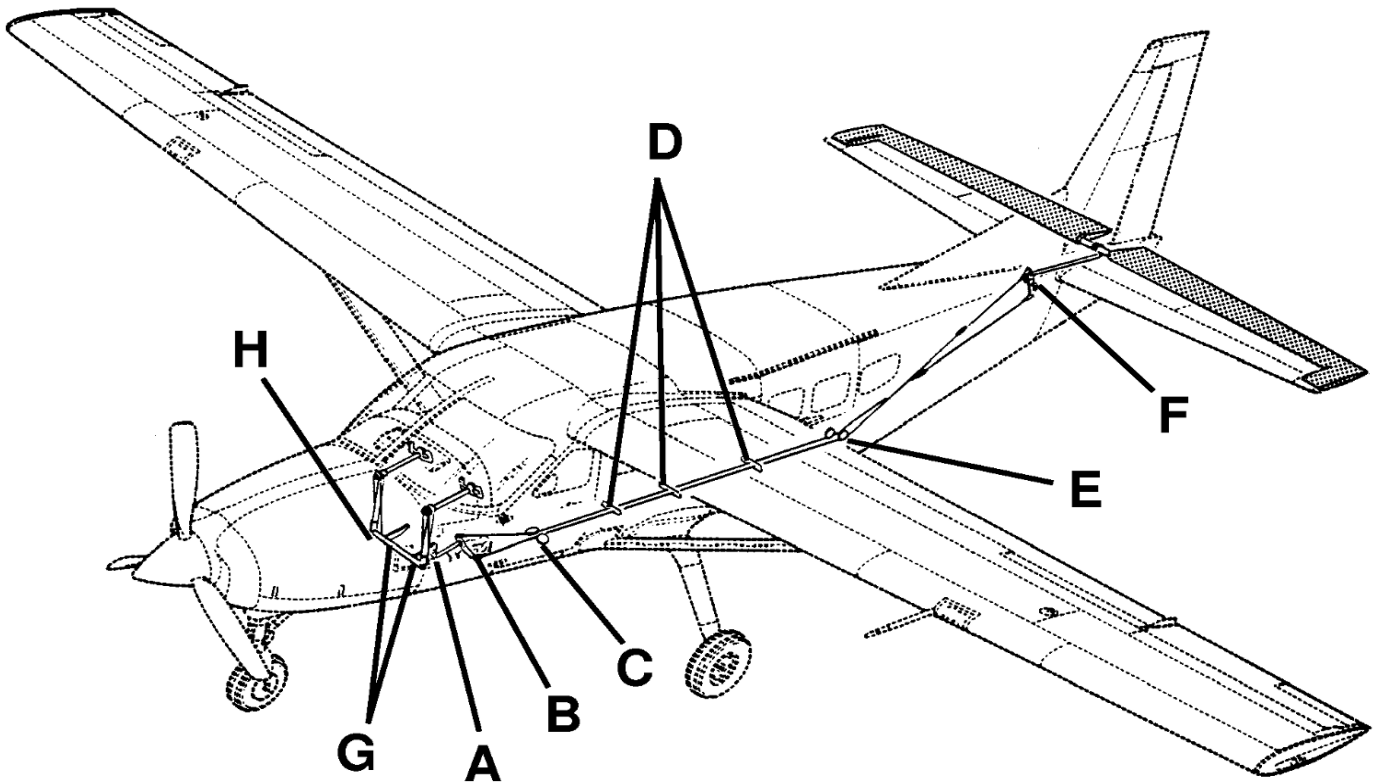

26631018

Figure 201 : Sheet 2 : Elevator System Installation

A22545

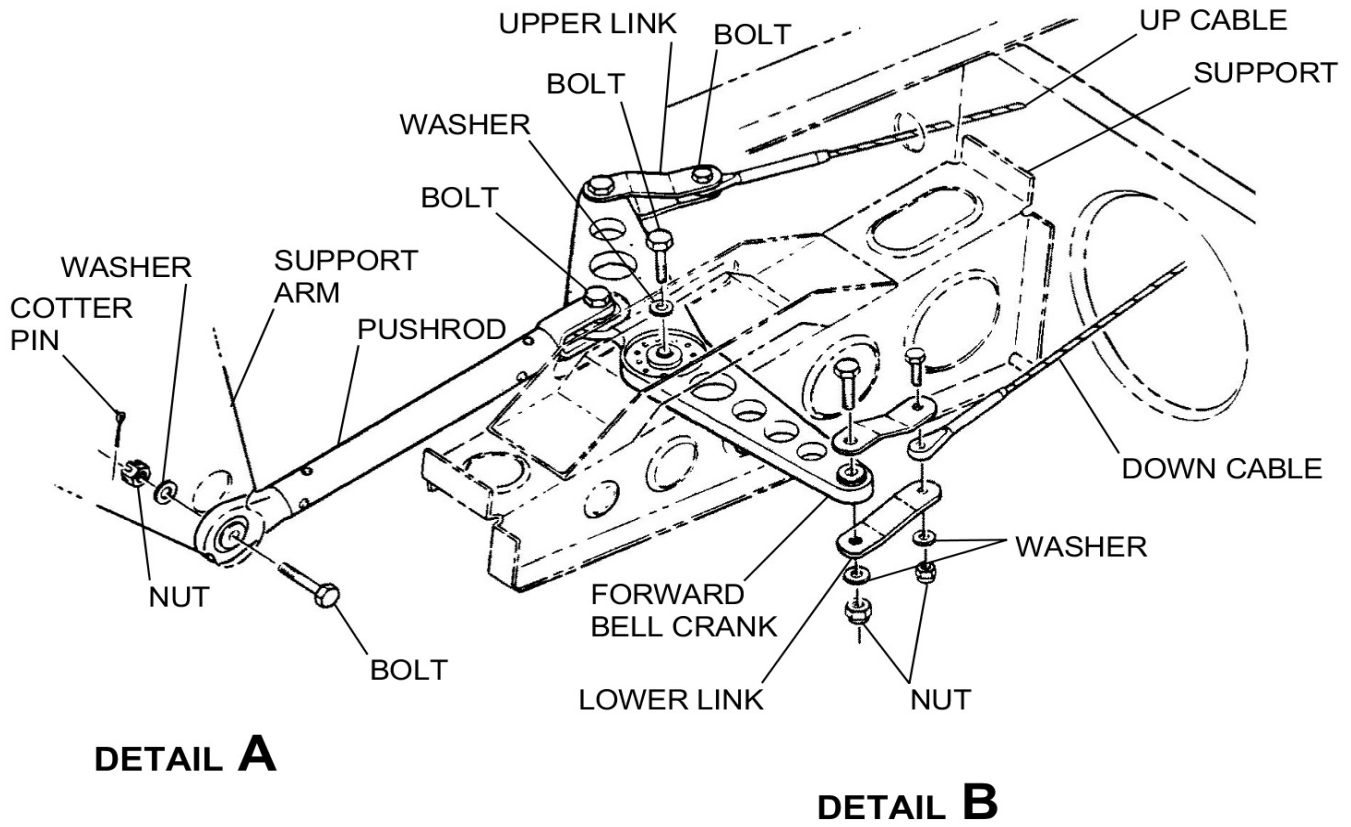

A2663R3012
B2663R2012

Figure 201 : Sheet 3 : Elevator System Installation

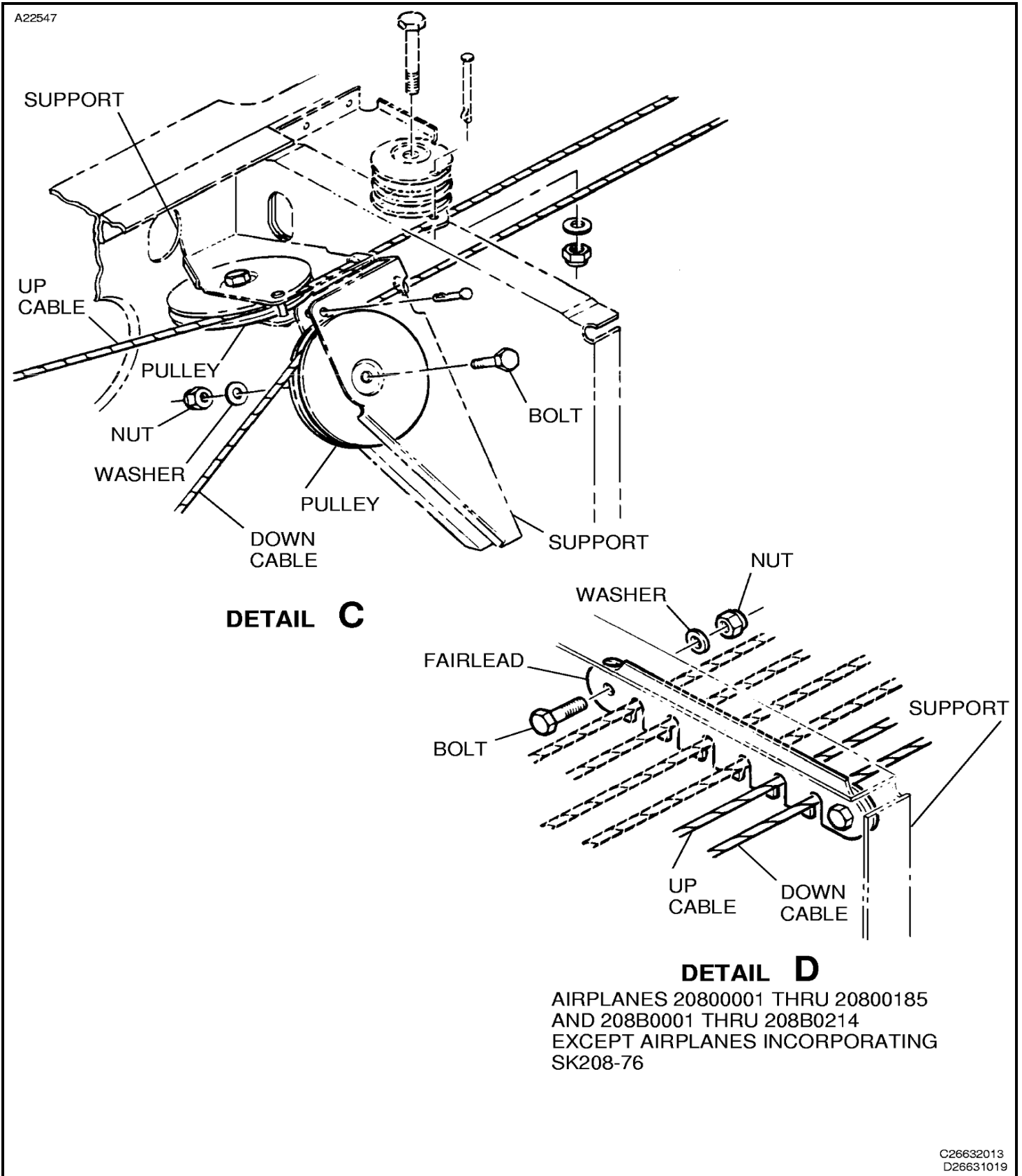
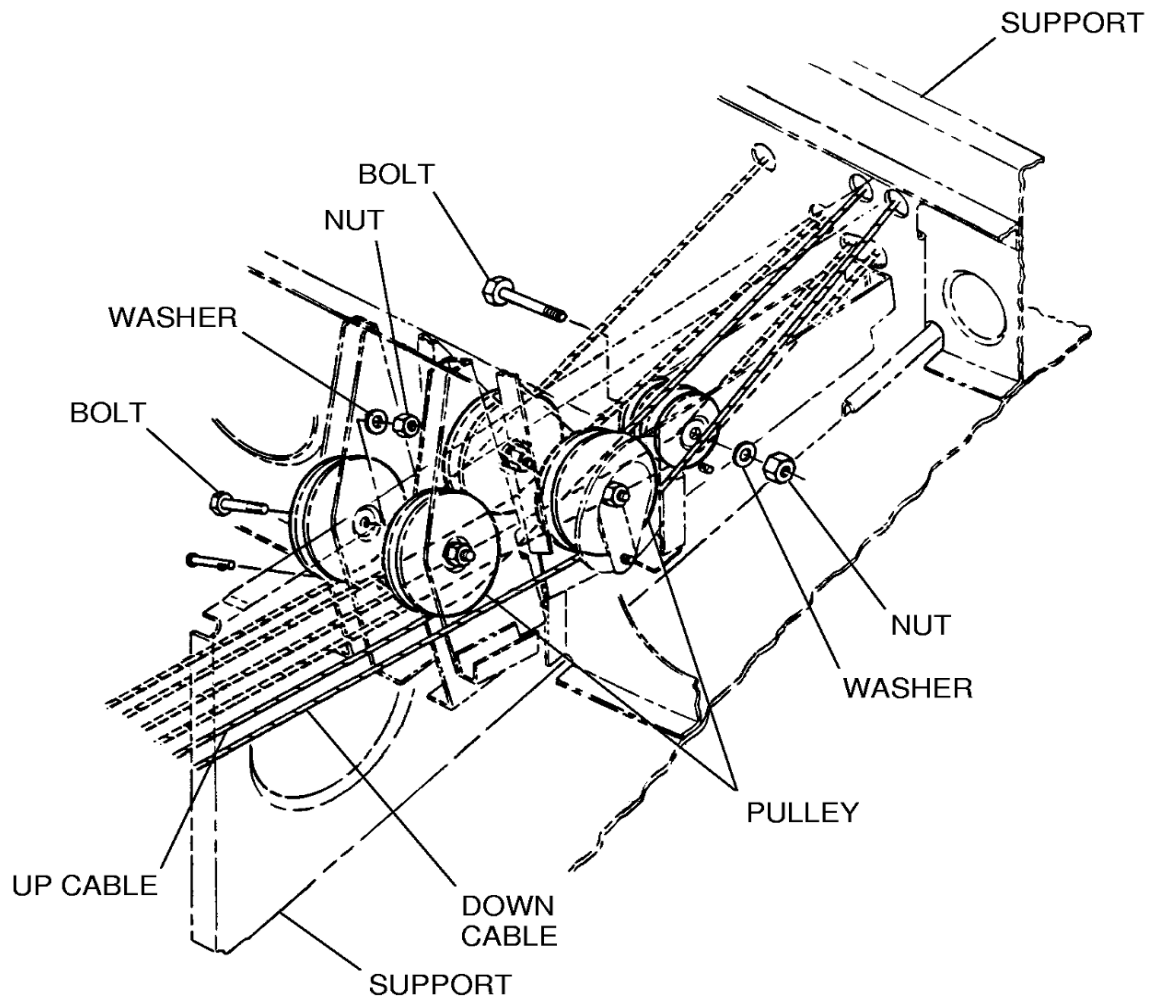

Figure 201 : Sheet 4 : Elevator System Installation

A22549



DETAIL E

E26632011

Figure 201 : Sheet 5 : Elevator System Installation

A22551

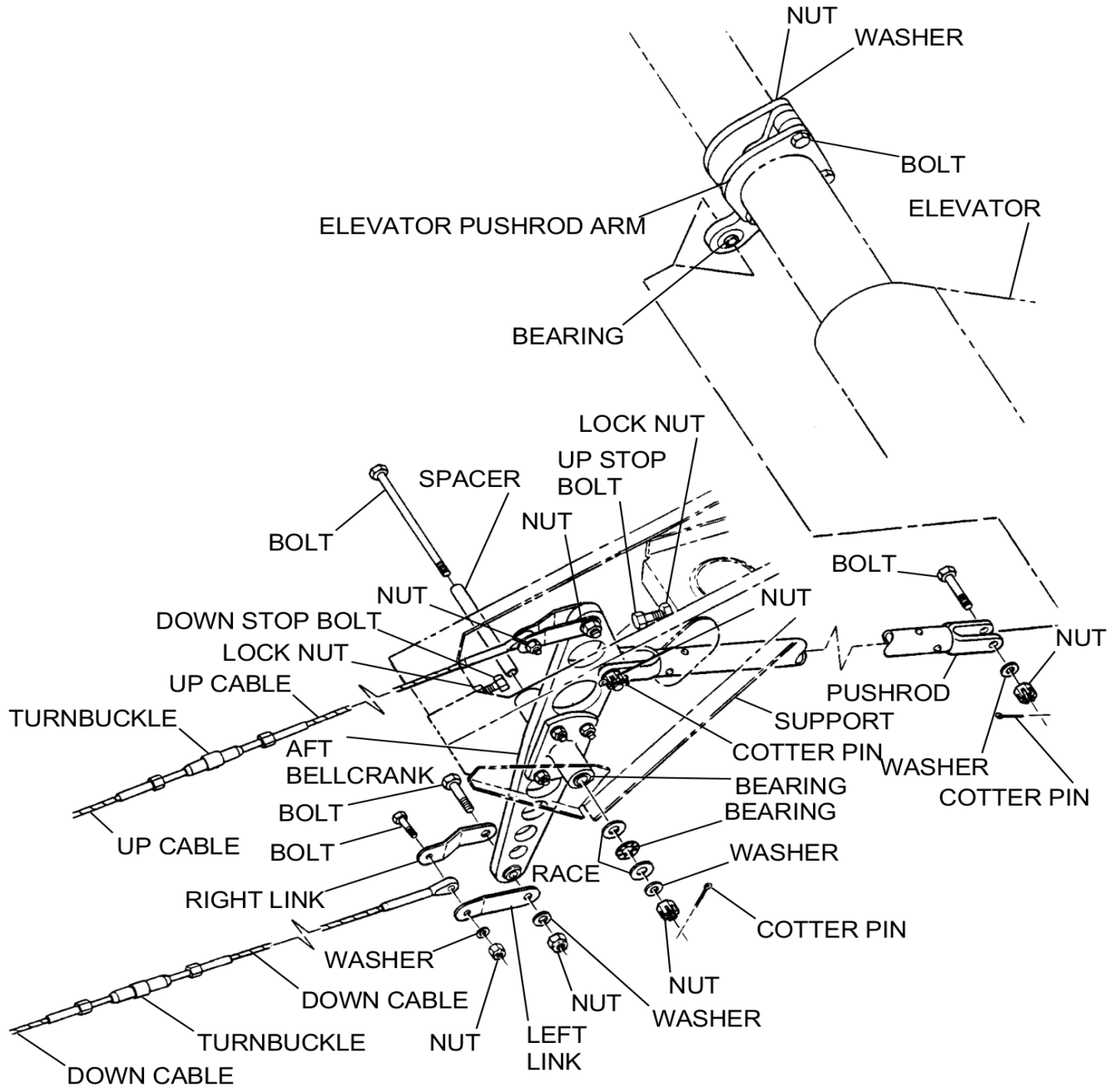

DETAIL F

F2663R3001A

Figure 201 : Sheet 6 : Elevator System Installation

A22552

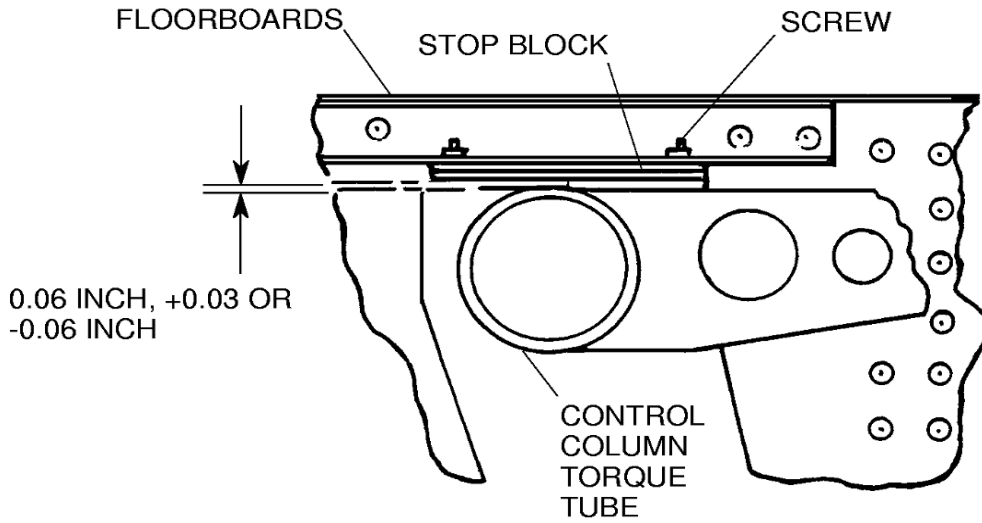

DETAIL G

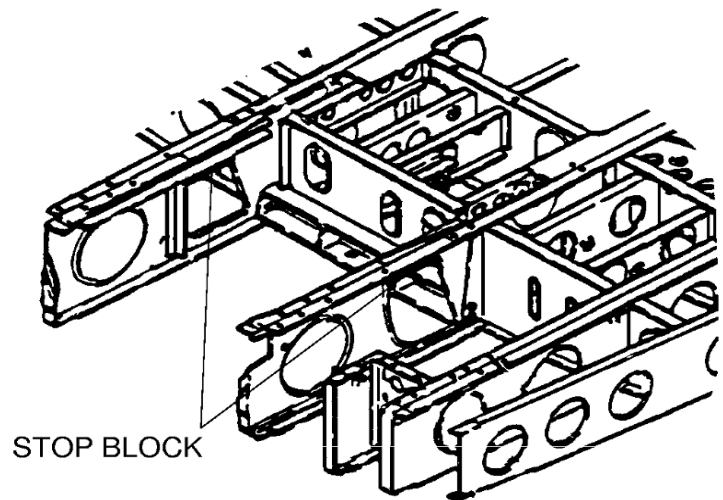

DETAIL H
BRITISH CERTIFIED AIRPLANES
208B0055 AND ON

AIRPLANES 20800130 AND ON
AND 208B0087 AND ON

G2663R1017
H2663R1018

Figure 201 : Sheet 7 : Elevator System Installation

A22553

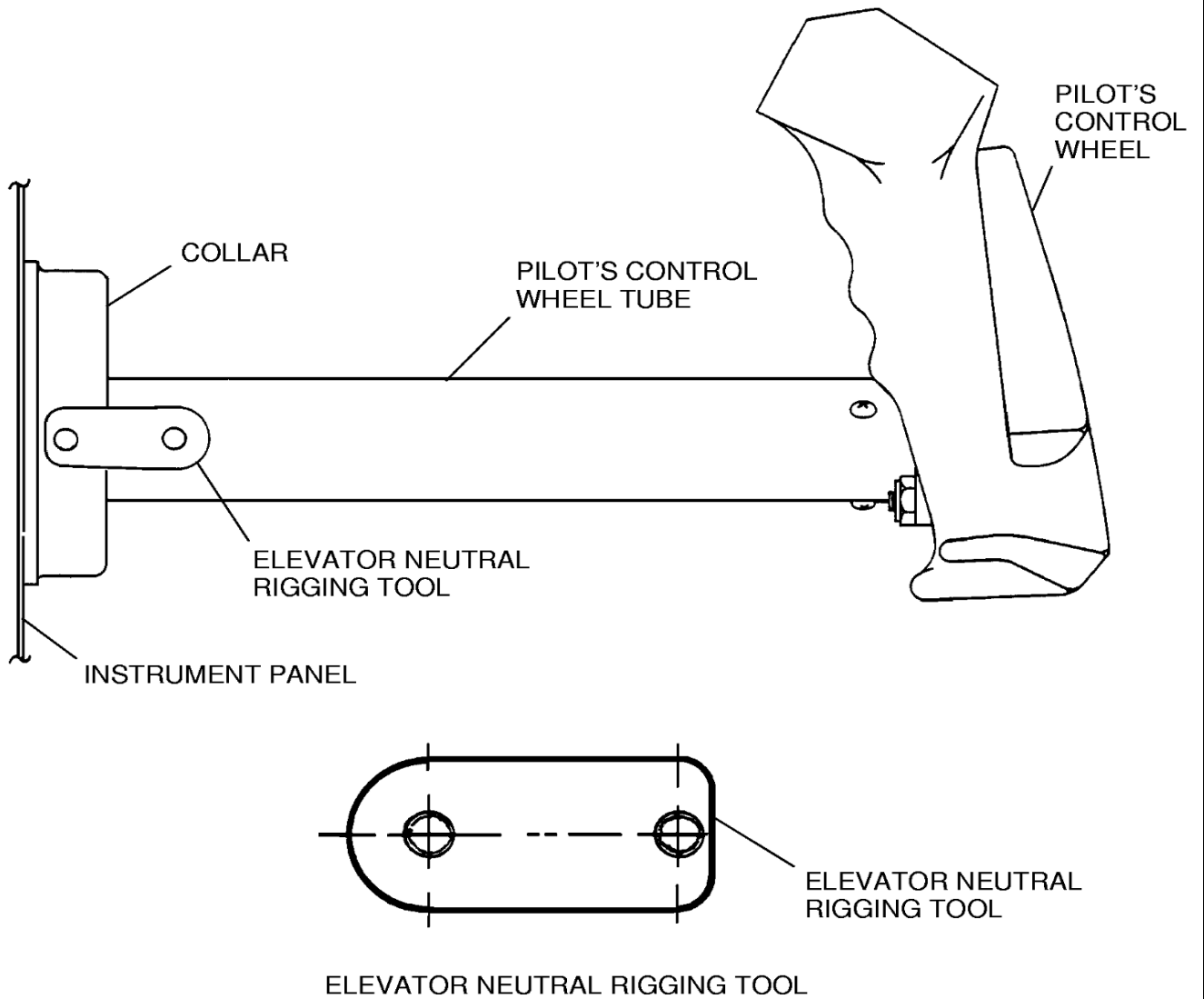

26632003
2663R1016

Figure 201 : Sheet 8 : Elevator System Installation

